

SP 725 EC-TH-L (DC)

We care.

Customised Pumps - No Additional Costs!

Product Features

- Miniature diaphragm pump for liquids
- Chemical resistant versions available
- Use with two media or in serial or parallel operation
- Durable iron core motor with ball bearings
- Low weight and small size
- Self-priming
- Low noise and reduced vibrations
- Installation in any mounting orientation allows simple device integration
- Oil-free and maintenance-free

Application Examples

- Industrial applications
- Medical applications
- Laboratory applications
- Analytical applications
- Cooling and heating
- Cleaning and disinfection
- Inkjet printers and reprography
- Fuel cells
- Pipetting
- Random access analyzers

and many more...

Customisation

- We offer your customised precision pump without additional costs - even for small batches
- Outstanding quality
- Excellent technical consultation and service by experts
- More than 40 years experience in pump applications
- Fast delivery - order your sample now!



Schwarzer
Precision



SP 725 EC-TH-L

The pumps listed below represent a typical selection of our wide range of eccentric pumps and are intended for initial tests. **Customised versions** for your individual application would be made without additional costs - please contact us! All flow values given under norm conditions (according to DIN 1343). Optional materials can cause deviating performance values.

Designation		SP 725 EC-TH-L (DC)	
Operating Voltage [Vdc]		12	24
Art.No.		7s54072	7s54073
Hydraulic Performance (measured with water at 20°C)			
Free Flow [ml/min]		1400	1400
Flow at 10 m H ₂ O [ml/min]		1100	1100
max. Pressure Height [m H ₂ O]		>10	>10
Although the pumps are able to produce pressure above 10 m H ₂ O, it is not recommended to exceed this limit!			
max. Suction Height (filled system) [m H ₂ O]		-5.0	-5.0
max. Vacuum (dry) [mbar]		-650	-650
Motor / Power Consumption			
Standard Motor		iron core / ball bearings	
max. Nominal Current [mA]		3500	1500
Optional Motor Type		-	-
Construction			
Pump Head	standard optional	PPS customer specific - upon request	
Diaphragm	standard optional	EPDM FKM	
Valves	standard optional	EPDM FKM	
Weight [g]		850	850

Performance Curves

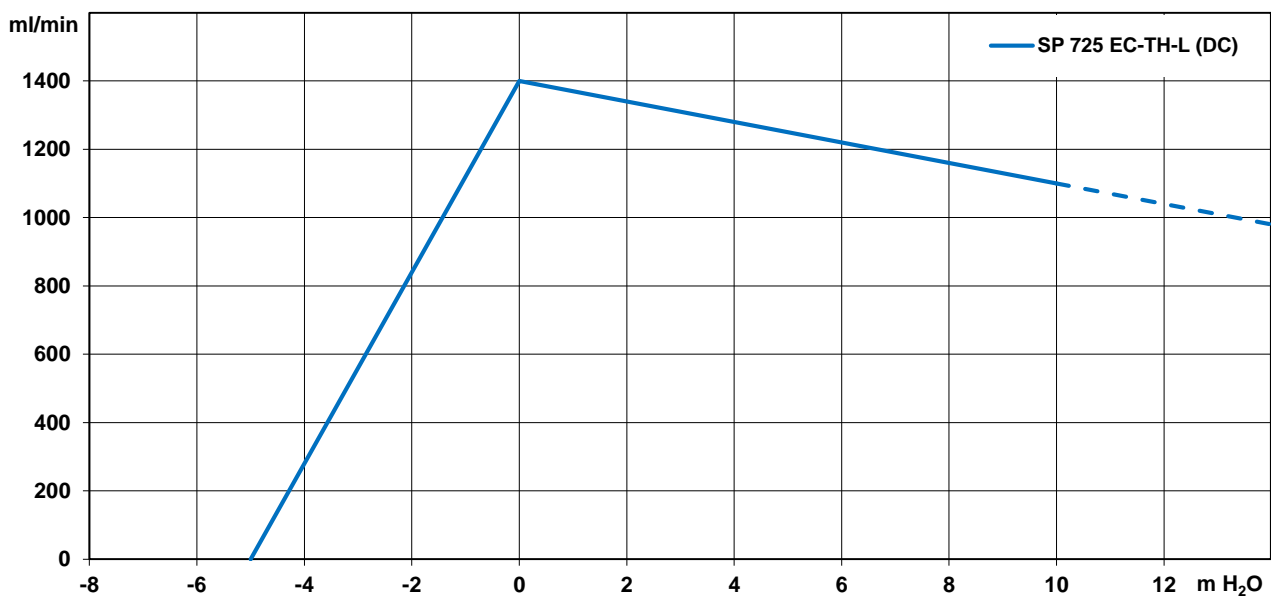

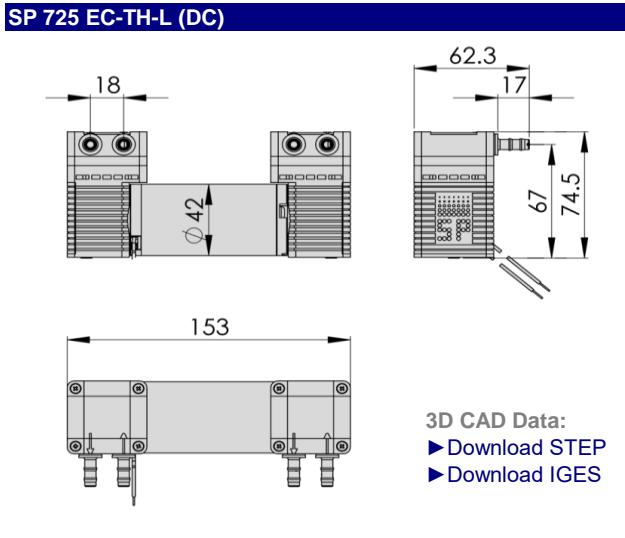

Standard: connection ports as shown
Optional: 3 other port positions possible

You can also download the 3D CAD data on the SP website:
▶ www.schwarzer.com/download

Tubing Diagram

Note: parallel operation only!
Serial operation can cause damage to the pump!

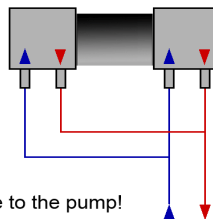



Customising Examples

Customising without compromises is extremely important to us. We develop precision pumps in direct collaboration with our customers - with all parameters exactly adapted to the respective application. Thanks to the modular pump design, this is done without added development-related costs! We develop the ideal pump for you. Uncompromising and reliable.

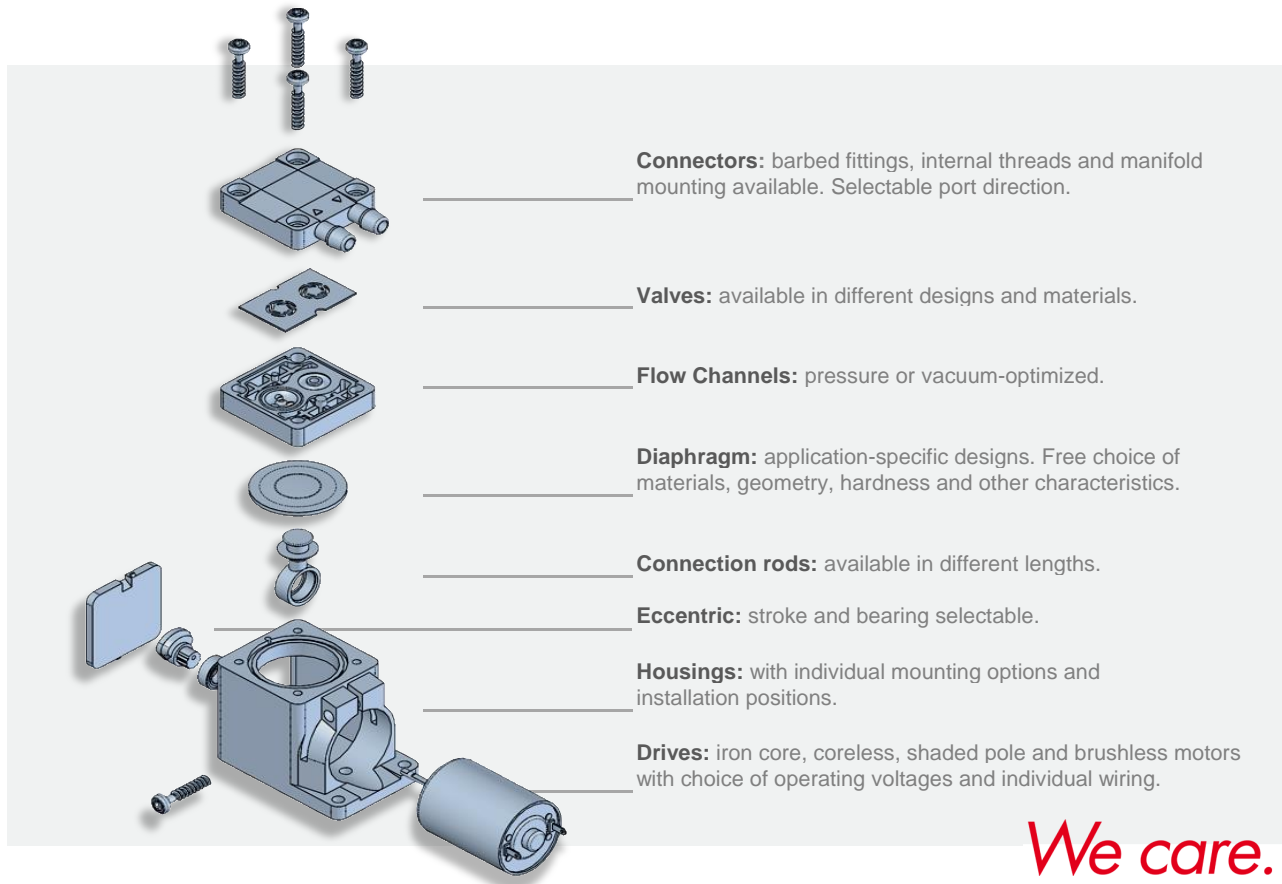

Installation Notes

In order to minimise noise and vibration we recommend securing the pump in one of the following ways:

- with rubber mounting (see "Accessories")
- with padded double sided adhesive tape
- with Velcro (hook and loop) tape for easy assembly and service
- Put the pump in a box lined with foam. Motor wires and tubing for the pump can lead through a hole in the side of the box.

Accessories

Schwarzer Precision offers a comprehensive portfolio of pump accessories such as:

- mountings
- silencers + filters
- electronics
- check valves + pressure switches