

SP 200 EC-LC



SP 250 EC

We care.

Customised Pumps - No Additional Costs!

Product Features

- Micro diaphragm pump for gases
- Applicable as vacuum or pressure pump
- FCV technology (fast closing valves)
- Available in common supply voltages
- From low-cost to durable brushless drives
- Low weight and very small size
- Applicable for noise- and vibration-sensitive environments (i.e. hospitals, personal protection equipment, etc.)
- Installation in any mounting orientation allows simple device integration
- Leak-tight, oil-free and maintenance-free

Application Examples

Particularly suitable for portable devices such as:

- Air sampling
- Gas sniffer
- Breath gas analysis
- Gas monitoring
- Personal gas detectors
- Exhaust analyzers
- Pneumatics
- Pipetting devices
- Fuel cells

and many more...

Customisation

- We offer your customised precision pump without additional costs - even for small batches
- Our modular concept allows easy adaptations
- Outstanding quality - Made in Germany
- Excellent technical consultation and service by experts
- More than 40 years experience in pump applications
- Manifold mounting
- Fast delivery - order your sample now!





The pumps listed below represent a typical selection of our wide range of eccentric pumps and are intended for initial tests. **Customised versions** for your individual application would be made without additional costs - please contact us! All flow values given under norm conditions (according to DIN 1343). Optional materials can cause deviating performance values.

Designation	SP 200 EC-LC	SP 250 EC
Operating Voltage [Vdc]	5	5
Art. No.	7s20091	7s20092
Pneumatic Performance		
Free Flow [ml/min]	600	420
Pressure Side		
Flow at 100 mbar [ml/min]	400	220
max. Pressure [mbar]	550	400
Vacuum Side		
Flow at -100 mbar [ml/min]	350	220
max. Vacuum [mbar]	-500	-450
Motor / Power Consumption		
Standard Motor Type	iron core / sintered bearings	skew wound / sintered bearings
max. Nominal Current [mA]	160	90
Optional Motor Type	-	ball bearings
Construction		
Pump Head	standard optional	PPS manifold mounting, customer specific (upon request)
Diaphragm, Valves	standard optional	EPDM FKM
Weight [g]	17	19

Performance Curves

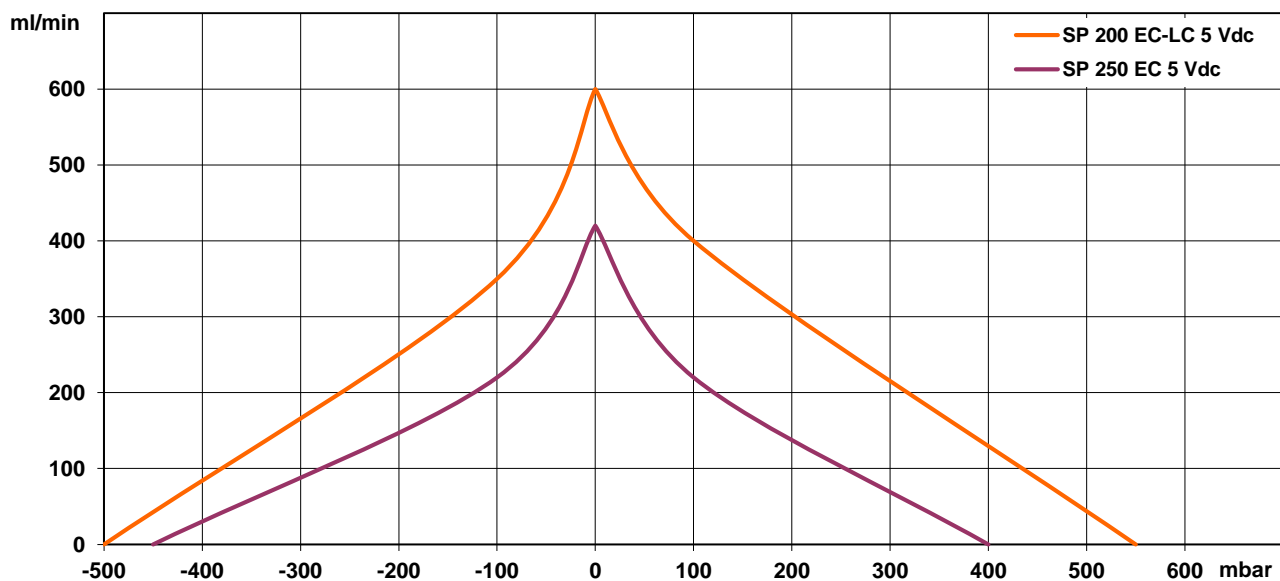



SP 200 EC-LC

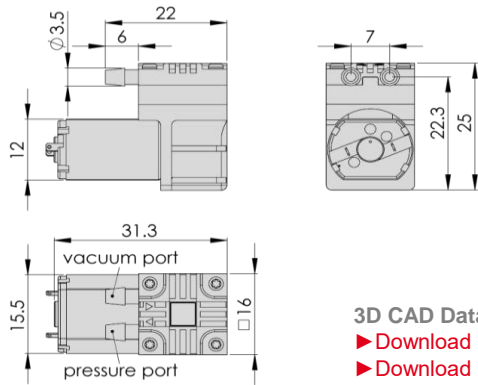

SP 250 EC

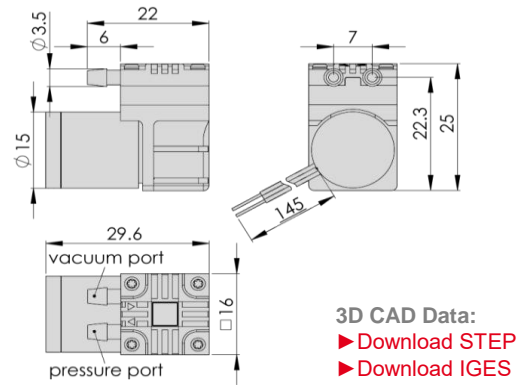

Optional: SP 200 EC-LC with Manifold Mounting

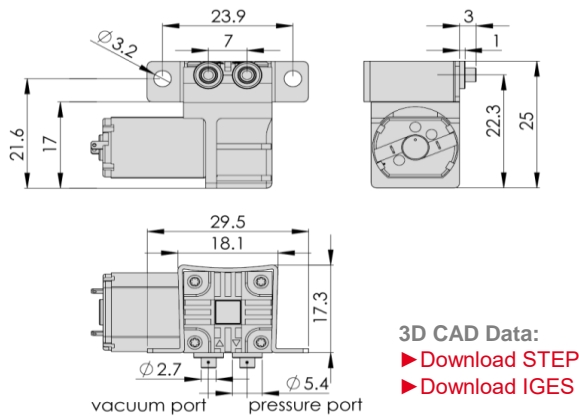

Standard: connection ports as shown
Optional: 3 other port positions possible

You can also download the 3D CAD data on the SP website:
▶ www.schwarzer.com/download



Customising Examples

Customising without compromises is extremely important to us. We develop precision pumps in direct collaboration with our customers - with all parameters exactly adapted to the respective application. Thanks to the modular pump design, this is done without added development-related costs! We develop the ideal pump for you. Uncompromising and reliable.

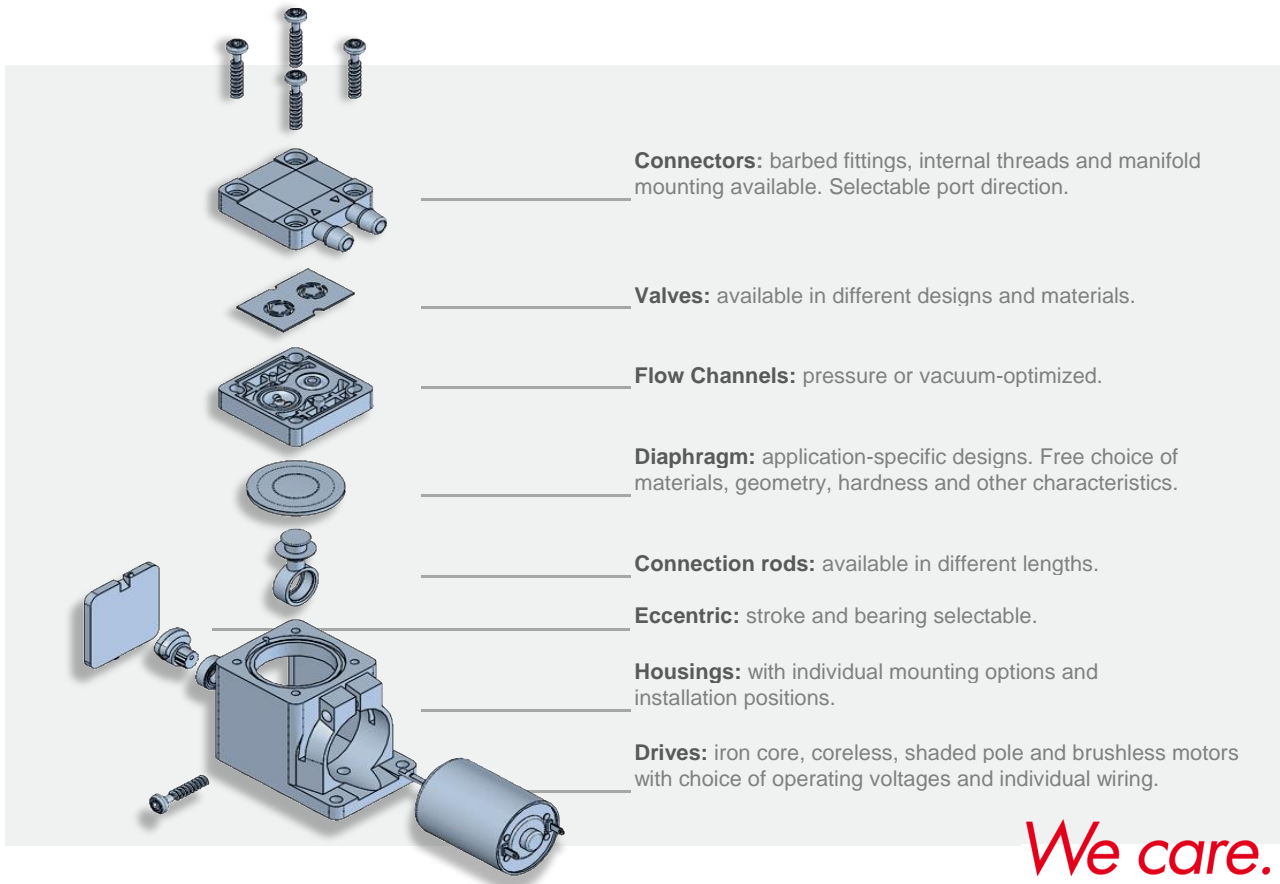

Installation Notes

In order to minimise noise and vibration we recommend securing the pump in one of the following ways:

- with rubber mounting (see "Accessories")
- with padded double sided adhesive tape
- with Velcro (hook and loop) tape for easy assembly and service
- Put the pump in a box lined with foam. Motor wires and tubing for the pump can lead through a hole in the side of the box.

Accessories

Schwarzer Precision offers a comprehensive portfolio of pump accessories such as:

- mountings
- silencers + filters
- electronics
- check valves + pressure switches